

Up to 720 mW Fiber Bragg Grating Stabilized 980 nm Pump Modules

S30 Series

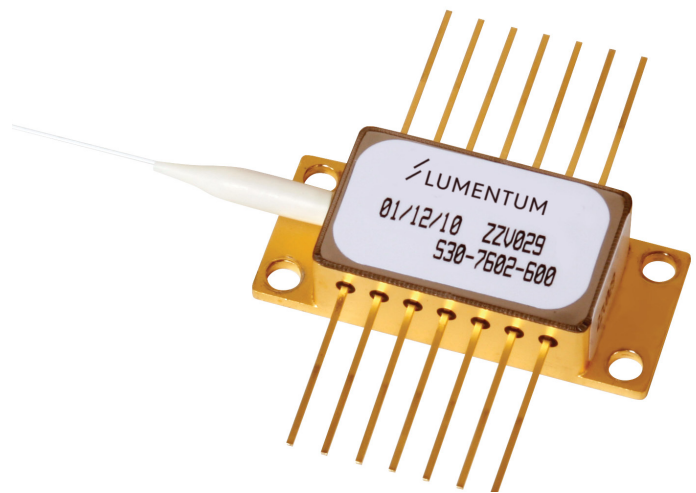

The Lumentum S30 Series pump laser module leverages a revolutionary design and lean manufacturing processes to significantly advance the performance and scalability of 980 nm pumps. The module meets stringent telecommunications industry requirements, including Telcordia GR-468-CORE for hermetic 980 nm pump modules.

The S30 Series pump module, which uses fiber Bragg grating stabilization to lock the emission wavelength, provides a noise-free, narrowband spectrum, even under changes in temperature, drive current, and optical feedback. Wavelength selection is available for applications requiring the highest performance in spectrum control with the highest power available.

Key Features

- Operating power range from 300 to 720 mW
- 25°C internal temperature, compatible with legacy temperature control
- Low-profile, 14-pin butterfly package
- Fiber Bragg grating stabilization
- Wavelength selection available
- Integrated thermoelectric cooler, thermistor, and monitor diode
- High dynamic range
- Excellent low power stability

Applications

- Dense wavelength division multiplexing (DWDM) EDFAs for small package designs
- High bit-rate and high channel-count EDFAs
- CATV distribution

Compliance

- Telcordia GR-468-CORE

Dimensions Diagram

(Specifications are in mm unless otherwise noted; tolerance = x. ±0.3, x.x ±0.25.)

CO package and UNC package are used in combination.

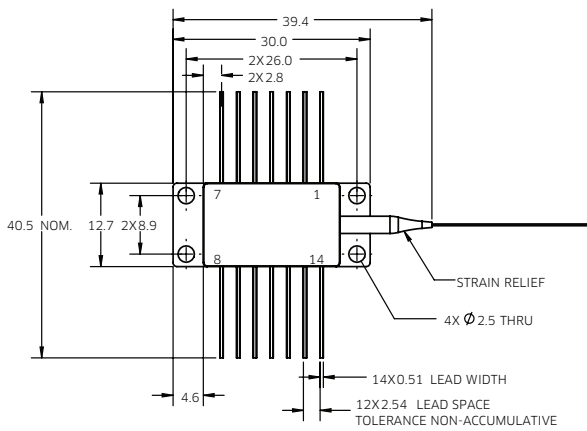

CO Package

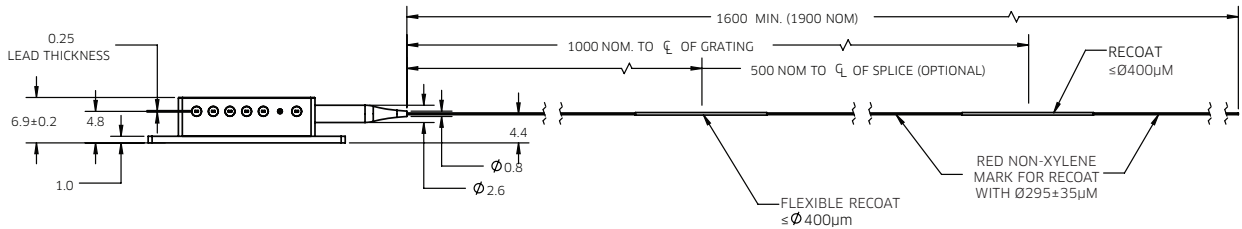
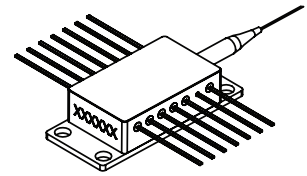
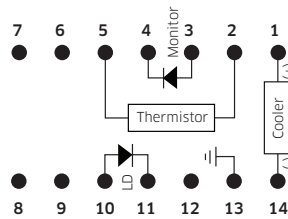

UNC Package

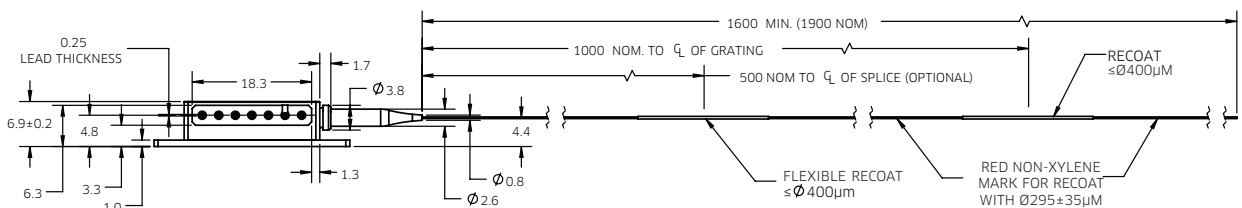
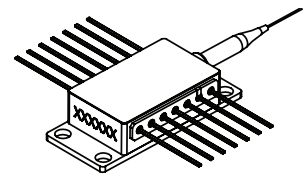
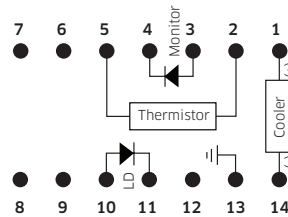
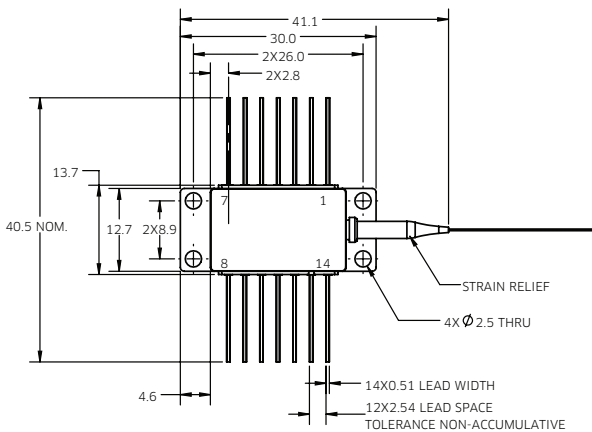

Pinout

Pin	Description
1	Cooler (+)
2	Thermistor
3	Monitor PD anode
4	Monitor PD cathode
5	Thermistor
6	N/C
7	N/C
8	N/C
9	N/C
10	Laser anode
11	Laser cathode
12	N/C
13	Case ground
14	Cooler (-)

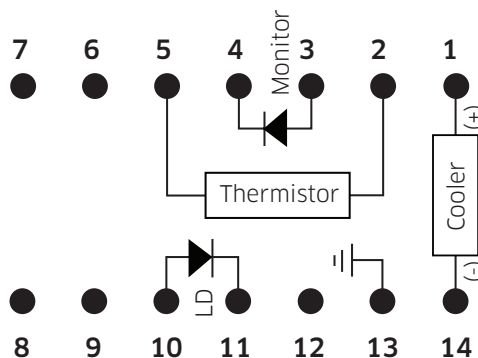

Table 1. Absolute Maximum Ratings

Parameter	Symbol	Test Conditions	Minimum	Maximum
Operating case temperature	T_{OP}		-5°C	75°C
Storage temperature	T_{STR}	2000 hr	-40°C	85°C
Laser operating temperature	T_{LD}		-5°C	50°C
LD reverse voltage	V_r			2.0 V
LD forward current	$I_{r,max}$			1450 mA
LD reverse current				10 μ A
PD reverse voltage	V_{PD}			20 V
PD forward current	I_{PF}			10 mA
LD electrostatic discharge (ESD)	V_{ESDLD}	C = 100 pF, R = 1.5 k Ω , human body model		1000 V
PD electrostatic discharge (ESD)	V_{ESDPD}	C = 100 pF, R = 1.5 k Ω , human body model		700 V
TEC current	I_{TEC}		-1.0 A	4.0 A
TEC voltage	V_{TEC}			4.5 V
Axial pull force		3 x 10 s		5 N
Side pull force		3 x 10 s		2.5 N
Fiber bend radius			16 mm	
Relative humidity	RH	Noncondensing	5%	95%
Lead soldering time		300°C		10 s

Absolute maximum ratings are the maximum stresses that may be applied to the module for short periods of time without causing damage. Stresses in excess of the absolute maximum ratings can cause permanent damage to the device. Exposure to absolute maximum ratings for extended periods of time or exposure to more than one absolute maximum rating simultaneously may adversely affect device reliability. Specifications may not necessarily be met under these conditions.

Table 2. Operating Parameters (BOL, $T_{case} = -5$ to 75°C, -50 dB reflection, unless otherwise noted.)

Product Code	Maximum Operating Power P_{op} (mW)	Maximum Operating Current I_{op} (mA)	Minimum Kink-Free Power P_{max} (mW)	Maximum Kink-Free Current I_{max} (mA)
S30-xxxx-300	300	630	330	640
S30-xxxx-320	320	655	360	700
S30-xxxx-340	340	680	380	760
S30-xxxx-360	360	720	400	805
S30-xxxx-380	380	760	420	855
S30-xxxx-400	400	805	440	890
S30-xxxx-420	420	860	460	940
S30-xxxx-440	440	890	480	985
S30-xxxx-460	460	920	505	1050
S30-xxxx-480	480	960	530	1100
S30-xxxx-500	500	1000	550	1150
S30-xxxx-520	520	1050	570	1200
S30-xxxx-540	540	1100	595	1250
S30-xxxx-560	560	1150	615	1300
S30-xxxx-580	580	1200	640	1350
S30-xxxx-600	600	1250	660	1400
S30-xxxx-620	620	1150	680	1300
S30-xxxx-640	640	1200	710	1350
S30-xxxx-660	660	1250	730	1400
S30-xxxx-680	680	1250	750	1400
S30-xxxx-700	700	1300	770	1450
S30-xxxx-720	720	1300	790	1450

The xxxx denotes the wavelength per the product code in Table 3.

Table 3. Available Peak Wavelength Selection

Product Code	Minimum Center Wavelength	Maximum Center Wavelength
S30-7402-yyy	973.0 nm	975.0 nm
S30-7602-yyy	975.0 nm	977.0 nm
S30-8000-yyy	973.0 nm	981.5 nm

The yyy denotes the operating power per the product code in Table 2.

Table 4. Electro-Optical Performance (BOL, $T_{\text{case}} = -5$ to 75°C , P_f range = 20 mW to P_{max} , -50 dB reflection, unless otherwise noted.)

Parameter	Symbol	Test Conditions	Minimum	Maximum
Threshold current	$I_{\text{th-BOL}}$			35 mA
Forward voltage	V_f	$I_f = I_{\text{op}}$		2.6 V
Fiber output power range	P_f		20 mW	P_{op}
Pump power in band	P_{pump}	$P_{\text{pump}} \text{ Band} = \lambda_m \pm 1.5 \text{ nm}$, at P_{op}	90%	
Spectral width	$\Delta\lambda_{\text{RMS}}$	$50 \text{ mW} < P_f < P_{\text{op}}$		2.0 nm
Wavelength tuning vs. temperature	$\Delta\lambda/T$	$I = I_{\text{op}}$		0.01 nm/ $^{\circ}\text{C}$
Optical power stability	$\Delta P_{f,t}$	Over P_f range, DC to 50 kHz, 20 mW to P_{op}		2.0%
Tracking ratio ¹	TR	$0.1P_{\text{op}} < P_f < P_{\text{op}}$	0.75	1.25
Tracking error ²	TE	At P_{op}	-25%	25%
Monitor diode responsivity	I_{BF}	At P_{op} , $V_{\text{PD}} = -5 \text{ V}$	1 $\mu\text{A}/\text{mW}$	5 $\mu\text{A}/\text{mW}$
Thermistor resistance	R_{th}	$T_{\text{set}} = 25^{\circ}\text{C}$	9.5 k Ω	10.5 k Ω
Thermistor constant	B		3600 K	4200 K

1. The tracking ratio is a measure of the front-to-back tracking when the output power is varied. On a plot of optical power versus back-face photocurrent, a straight line is drawn between the minimum power (20 mW) and the operating power (P_{op}) points. The tracking ratio is defined as the ratio between measured optical power (shown as data points on the plot) to the value derived from the straight line.
2. The tracking error is defined as the normalized change of output power relative to the operating power over case temperature range (0 to 75°C), at constant back-face monitor current corresponding to the operating power at 25°C .

Table 5. TEC and Total Module Power Consumption (BOL for $\Delta T = 30^\circ\text{C}$, $T_{\text{case}} = 75^\circ\text{C}$, $T_{\text{LD}} = 25^\circ\text{C}$)

Product Code	TEC Current I_{max} (A)	TEC Voltage V_{max} (V)	TEC Power Consumption P_{TEC} (W)	Total Module Power Consumption P_{max} (W)
S30-xxxx-300	1.67	2.24	3.25	4.36
S30-xxxx-320	1.70	2.27	3.48	4.71
S30-xxxx-340	1.74	2.31	3.70	5.06
S30-xxxx-360	1.77	2.34	3.85	5.32
S30-xxxx-380	1.81	2.38	4.20	5.78
S30-xxxx-400	1.86	2.43	4.50	6.21
S30-xxxx-420	1.91	2.48	4.88	6.77
S30-xxxx-440	1.96	2.53	5.05	7.05
S30-xxxx-460	1.98	2.54	5.38	7.21
S30-xxxx-480	2.03	2.60	5.55	7.48
S30-xxxx-500	2.09	2.65	5.64	7.69
S30-xxxx-520	2.12	2.67	5.77	7.96
S30-xxxx-540	2.18	2.74	5.91	8.26
S30-xxxx-560	2.21	2.76	6.06	8.56
S30-xxxx-580	2.28	2.84	6.19	8.84
S30-xxxx-600	2.31	2.85	6.38	9.19
S30-xxxx-620	2.21	2.76	6.06	8.56
S30-xxxx-640	2.28	2.84	6.19	8.84
S30-xxxx-660	2.31	2.85	6.38	9.19
S30-xxxx-680	2.35	2.90	6.82	10.32
S30-xxxx-700	2.41	2.95	7.11	10.73
S30-xxxx-720	2.50	3.10	7.75	11.38

Table 6. HI 1060 Fiber Nominal Characteristics and Tolerances

Parameters	Specification
Cutoff wavelength	920 nm
Maximum attenuation at 980 nm	2.1 dB/km
Cladding outside diameter	125 \pm 1 μm
Coating outside diameter	245 \pm 10 μm
Core-cladding concentricity	\leq 0.5 μm
Mode field diameter	5.9 \pm 0.3 μm

User Safety

Safety and Operating Considerations

The laser light emitted from this laser diode is invisible and may be harmful to the human eye. Avoid looking directly into the fiber when the device is in operation.

CAUTION: THE USE OF OPTICAL INSTRUMENTS WITH THIS PRODUCT INCREASES EYE HAZARD.

Operating the laser diode outside of its maximum ratings may cause device failure or a safety hazard. Power supplies used with this component cannot exceed maximum peak optical power.

CW laser diodes may be damaged by excessive drive current or switching transients. When using power supplies, the laser diode should be connected with the main power on and the output voltage at zero. The current should be increased slowly while monitoring the laser diode output power and the drive current. Careful attention to heatsinking and proper mounting of this device is required to ensure specified performance over its operating life. To maximize thermal transfer to the heatsink, the heatsink mounting surface must be flat to within .001inch and the mounting screws must be torqued down to 1.5 in/lb.

ESD PROTECTION—Electrostatic discharge (ESD) is the primary cause of unexpected laser diode failure. Take extreme precaution to prevent ESD. Use wrist straps, grounded work surfaces, and rigorous antistatic techniques when handling laser diodes.

Laser Safety

The Lumentum pump laser module emits hazardous invisible laser radiation.

Due to the small size of the pump module, the box packaging is labeled with the laser radiation hazard symbol and safety warning label shown below.

This component requires provisions of drive and control electronics before emitting laser radiation.

Laser classification depends on the system control circuit and laser safety features provided.

This diode-pumped laser module is not 21CFR 1040.10 or IEC 60825-1:2014 certified. It is a component intended for system integration. Compliance with 21CFR 1040.10 and/or IEC 60825-1:2014 will need to be determined at the system level.

Lumentum has registered this laser with the FDA/CDRH as an OEM component. Please contact Lumentum for an FDA/CDRH accession number for this laser component.

Labeling



Laser radiation safety warning
Laser classification per IEC 60825-1:2014
Maximum output power 2 W



Module label



Box label

Ordering Information

For more information on this or other products and their availability, please contact your local Lumentum account manager or Lumentum directly at customer.service@lumentum.com.

Telcordia is a registered trademark of Telcordia Technologies Incorporated.

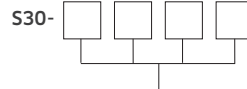

Peak Wavelength	Code
973.0 to 975.0 nm	7402
975.0 to 977.0 nm	7602
973.0 to 981.5 nm	8000

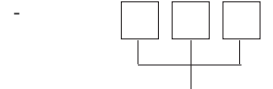

Maximum Operating Power	Code
300 mW	300
320 mW	320
340 mW	340
360 mW	360
380 mW	380
400 mW	400
420 mW	420
440 mW	440
460 mW	460
480 mW	480
500 mW	500
520 mW	520
540 mW	540
560 mW	560
580 mW	580
600 mW	600
620 mW	620
640 mW	640
660 mW	660
680 mW	680
700 mW	700
720 mW	720



North America
Toll Free: 844 810 LITE (5483)

Outside North America
Toll Free: 800 000 LITE (5483)

China
Toll Free: 400 120 LITE (5483)

© 2026 Lumentum Operations LLC
Product specifications and descriptions in this document are subject to change without notice.